

SOLO PLUS-MKII

WOOD-FIRED GASIFICATION
ADD-ON BOILER



SETTING THE STANDARD FOR EXCELLENCE IN WOOD-BURNING BOILERS



The HS-TARM Solo Plus-MKII Wood-Fired Gasification Add-On Boiler



Solo Plus, a patented, wood-fired gasification boiler. Three sizes available with outputs from 100,000 - 198,000 BTU/hr.

- Very high overall efficiency, 75-80%
- Environmentally friendly - super clean burn with virtually no smoke or creosote
- Large firebox
- Simple operation - easy to clean, very little ash

Combustion is regulated by a thermostatically controlled draft blower that forces combustion air into the boiler's ceramic combustion tunnel. Here, unusually effective combustion takes place at very high temperatures allowing the Solo Plus to use very little fuel in comparison to "conventional" boilers.

Feel good about heating with wood without becoming a slave to a heater that needs a mountain of wood to keep you warm.

HS-TARM Solo Plus boilers provide a convenient, safe and environmentally friendly way to heat your home and domestic hot water with wood. Solo Plus boilers assure the independence and selfreliance that heating with wood provides. Because they use the "magic" of wood gasification combustion, they give unusually high overall heating efficiency. They use substantially less wood than conventional boilers and outdoor water stoves. They burn so clean, they are safer (virtually no risk of a chimney fire) and result in cleaner air for everyone. They also help to substantially reduce greenhouse gas emissions. HS-TARM Solo Plus boilers enable you to increase the warm security of your home in a safe, envi-

ronmentally responsible way. Everyone wins!

For more than 70 years, HS-TARM has been a pioneer in the development and production of residential central heating equipment. HS-TARM's primary objective is quality, function and appearance... excellence at all levels. In fact, HS-TARM has earned the prestigious ISO 9001 certification, which assures consistently reliable product quality.

Operational reliability, unique firing efficiency, total quality and concern for the environment are all factors that have been instrumental in HS-TARM becoming an internationally recognized supplier of central heating boilers.

How the Solo Plus-MKII Works

The combustion system employed in Solo Plus boilers solves most of the problems associated with conventional wood boilers and outdoor water stoves.

Here's why: The wood gasification combustion process in the Solo Plus boiler begins when the small, quiet draft fan turns on in response to the boiler's heat controls. The draft fan blows fresh air into the top of the firebox and down through the wood and live charcoal bed. This hot air and smoke mixture is forced through a slot in the top of the ceramic combustion chamber. Super-heated secondary air is then injected into these gases. The combination of the wood gas and smoke with the high temperature oxygen results in a super-hot 1800' flame in the ceramic combustion tunnel. This is the 'Wow, that's unbelievable' process we call wood gasification. The gases stay in this hot turbulent environment long enough to achieve extremely high combustion efficiency. The resultant heat passes into the vertical heat exchange tubes giving off heat to the boiler water for house heating and domestic hot water demands. The combination of optimum combustion and maximum heat exchange efficiency is what yields the unusually high overall heating efficiency.

Heat Storage

Some Solo Plus boilers are installed without additional heat storage. The Solo Plus cycles on and off to maintain constant boiler temperature and to provide the

heat desired. Greater operating flexibility and even higher efficiency can be achieved through use of additional heat storage. This allows the boiler to be burned at full output until the full load of wood is consumed. When the house doesn't need all of the heat produced during this full hot burn, the unneeded heat will be stored for use at a later time.

Boiler Size

The heat loss of the house to be heated as well as the heat value of the firewood to be used should be considered when selecting a boiler. Your heat loss can be accurately calculated. As well, fueling with higher density hardwoods such as oak, beech and maple will result in longer burn times than fueling with softwoods. If softwood will be the primary type of firewood you may want to consider selecting a larger Solo Plus boiler with a larger firebox.

Safety and Clean-Air Tested

HS-TARM Solo Plus boilers have been developed in close cooperation with leading safety and air quality authorities. The many years of experience have given HS-TARM a big lead in the design and development of the Solo Plus over other wood-fired units. The Solo Plus has been tested and certified by safety, air quality and consumer organizations both in Europe and the USA. The results are so outstanding that the Solo Plus uniquely differs from all other solid fuel boilers.

▼ **Solid Material.** The internal boiler is made of fully welded plate steel 7-mm thick. There are many stays that reinforce the external boiler plate. HS-TARM boilers are constructed to very high quality standards and are designed for pressurized systems.

HS-Tarm Solo Plus-MKII

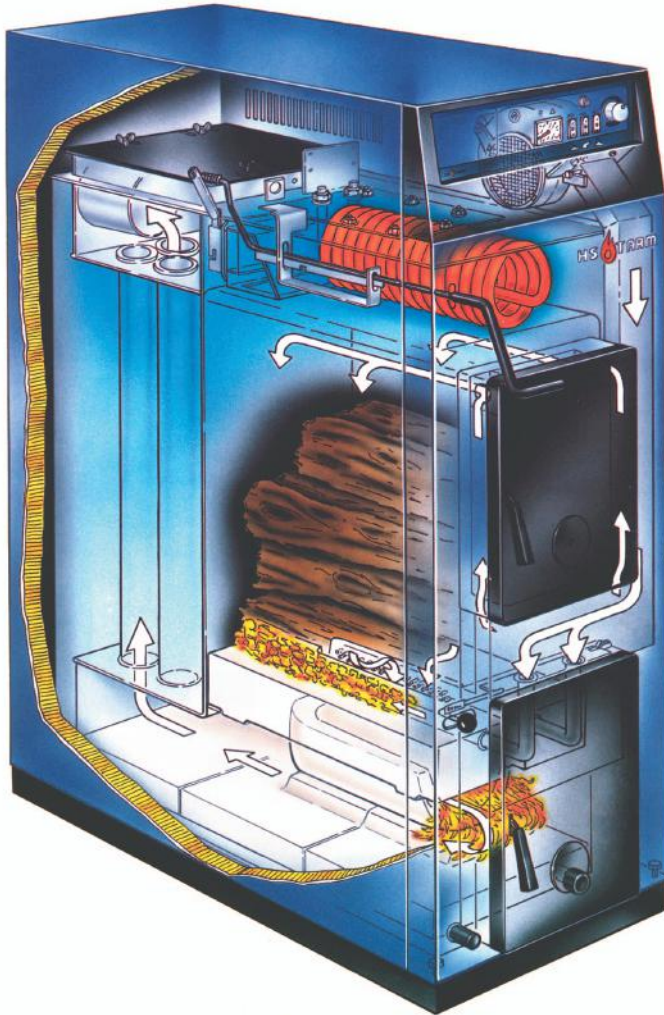

▼ **Large Heat Exchanger.** The 3-inch vertical heat exchange tubes are sized to fully exploit the exhaust gases produced by the high temperature combustion. Cleaning is easy through the large access cover.

▼ **Effective Air Distribution Gives Optimum Combustion.** Both the primary and secondary air are directed via air channels into the firebox at precise volume to produce optimum combustion. The primary air is fed into the uppermost part of the firebox. The secondary air is fed through the ceramic refractory, where it is heated and distributed to the double row of air nozzles located at each side of the refractory slot. The secondary air is then injected at high velocity directly into the flame in order to complete the combustion process.

▼ **Tankless Hot Water Coil.** Finned copper coil provides hot water for household use (optional.)

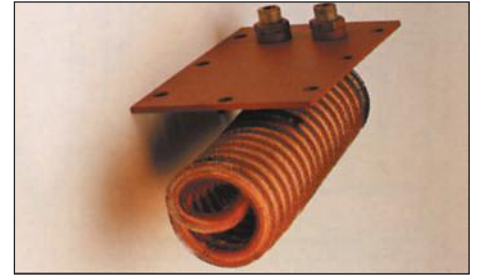

▼ **Combustion Fan.** This heavy-duty, quiet fan consumes less than 10 watts of electricity while providing the draft needed to achieve high efficiency.

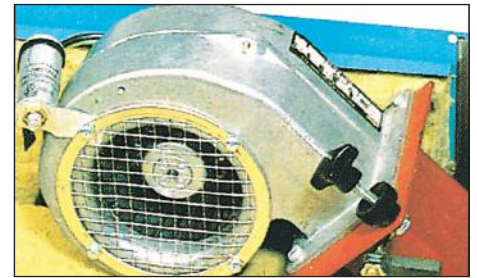

▼ **Ceramic bricks.** These bricks make up the heart of the system. Special air injection holes built into these ceramics provide the oxygen needed for complete combustion.



▼ **Combustion Tunnel.** This is where the magic of "wood gasification" occurs. This is the view you will get when you look into the observation port on the lower door. Temperatures of over 2000 degrees are achieved, therefore utilizing all available energy in the wood.

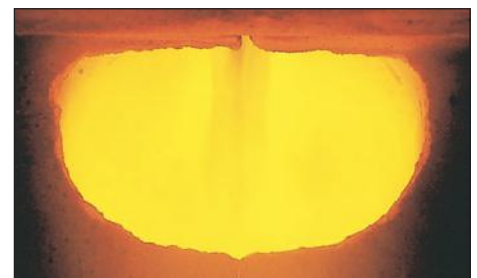

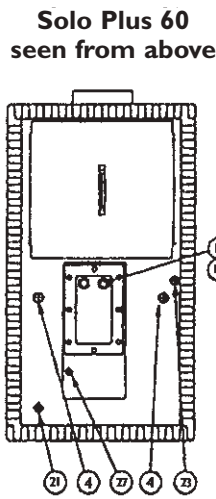
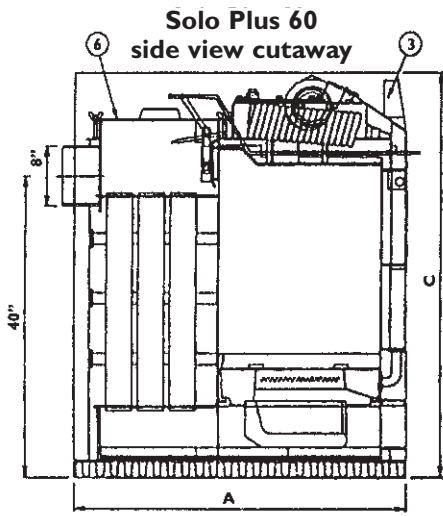

Solo Plus 30-40-60 seen from behind

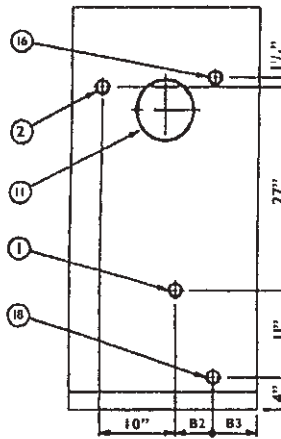

Solo Plus 30-40-60 seen from front

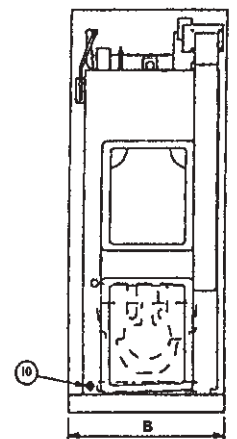

Standard Equipment

Boiler, jacket with insulation, cast iron doors with gasketing, draft inducer fan, relief valves, and boiler control as well as cleaning implements and manual.

Optional Equipment

- Heat Storage System
- Domestic hot water coil
- Enhanced ash pan

System Applications

- Baseboard hot water
- Radiant floor
- Hot air
- Add-on to oil or gas, or use as a stand alone boiler

20-Year Warranty

Each HS-TARM boiler is covered by a 20-year limited warranty. A copy is available for your inspection and is provided with each boiler.



HS-TARM boiler with Heat Storage System.

Solo Plus 30-40 side view cutaway

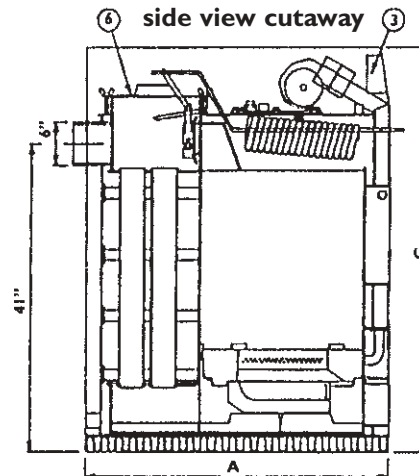

Solo Plus 30-40 seen from above

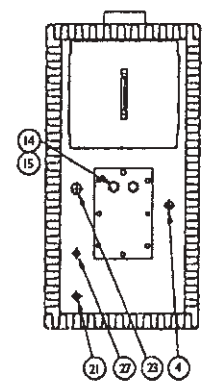

Technical Data:				
HS Solo-Plus		30	40	60
Maximum heat/output:	BTU/hr.	100,000	140,000	198,000
Firebox depth	inches	21	21	21
Load door	in. x in.	10 x 12	10 x 12	10 x 12
Firebox volume	cubic feet	4.01	5.35	6.01
Maximum wood length	in.	20	20	20
Test pressure boiler	PSI	65	65	65
Installation Data:				
Length (depth) A	in.	41	41	45
Breadth B	in.	21	25	25
Height C	in.	54	54	54
Height to center of flue	in.	41	41	40
Weight, empty	lb.	1060	1160	1210
Water contents	gal.	41	54	60
Flue collar, diameter	in.	6	6	8
1. Return	in.	1 1/4	1 1/4	1 1/4
2. Flow	in.	1 1/4	1 1/4	1 1/4
3. Control Panel	volts	110	110	110
4. Tapping - overheat	in.	3/4	3/4	3/4
5. Cleaning cover	4 thumb screws	x	x	x
10. Extra tapping	in.	1/2	1/2	1/2
11. Flue collar	in.	6	6	8
16. Expansion & extra flow	in.	1 1/4	1 1/4	1 1/4
18. Extra return	in.	1 1/4	1 1/4	1 1/4
21. Tapping - control panel	in.	1/2	1/2	1/2
23. Tapping - pressure gauge	in.	3/4	3/4	1/2
27. Vent	in.	3/8	3/8	3/8
Dimension, B2	in.	2 1/2	4 1/4	5
Dimension, B3	in.	3 3/4	6	4
Storage tank, ideal vol.	gal.	600	800	950

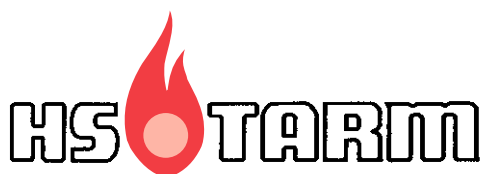

TARM USA INC

5 Main Street, Lyme, NH 03768

tel: (603) 795-2214 fax: (603) 795-470

tarm@valley.net www.woodboilers.com

