

central heat from coal

TARM 202

TARM 303



Coal is America's most abundant energy resource.

As oil and gas become increasingly expensive, many Americans are turning to coal. Now you can take full advantage of this low-cost fuel to meet all your heating needs — with the TARM 202 or TARM 303.

The TARM 202 or TARM 303 coal-fired boiler can be used in any hot water, central heating system. When you add the TARM 202 or TARM 303 to your present oil- or gas-fired system, you can heat your entire home with coal. When you're not burning coal, your system automatically switches to operation on oil or gas to guarantee uninterrupted heat.

The TARM 202 and TARM 303 are versatile as well. Should you run out of coal, you can switch to wood; the firebox accommodates chunks, scraps or, when loaded vertically, standard 16" firewood. And to save even more money on fuel, you can use your TARM 202 or TARM 303 to heat your tap water during the heating season or year 'round. With all the quality and craftsmanship you've come to expect from HS TARM, the TARM 202 or TARM 303 gives you a heating system unmatched in performance and durability.



HS • TARM

choose the system that is right for you . . .

TARM 202

If you believe that you shouldn't have to spend lots of money to save money on fuel, the TARM 202 is for you. This sophisticated central heating system is priced lower than many woodstoves, and at today's fuel prices, you can recover your initial cost in just a few years by burning coal. We invite comparison, either on the basis of quality, features or even "cost per pound" with any heating system on the market.

Although the design of both the firebox and heat exchanger contribute to the compactness of the TARM 202, no compromise has been made in the efficiency of these critical components. The tall, rectangular firebox holds enough coal for over 10 hours of burning at maximum output and up to 24 hours burn time at lower outputs. The horizontal watertube heat exchanger assures fast warm-up and quick acceleration to maximum outputs. Both the watertubes and the firebox are cleaned easily through the ash and loading doors.

The TARM 202 is the ideal coal-fired system for a small to medium-sized, well-insulated house. Its design provides for easy installation where space might otherwise be a problem. Since the flue outlet is vertical, the boiler can be placed directly against a chimney, and the front and side locations of tappings for pipe connections eliminate the need for rear access. The TARM 202 is shipped completely assembled and crated and can be installed easily where narrow clearances make access a problem.

TARM 303

For heating medium-sized and large homes as well as small commercial buildings, the TARM 303 represents 60 years of progress in the design of coal-burning combustion systems.

The TARM 303 firebox, with a generous ash pit below the cast-iron shaker grate, is round. As coal requires more heat than wood both to ignite and keep burning, this firebox is ideally shaped; a round firebox loses less heat to boiler water than a low, rectangular firebox of the same volume and thus helps maintain the critical temperature required for a lasting fire.

But whereas traditional coal-burning systems had a round firebox, they invariably lacked an efficient heat exchanger, causing much heat to be wasted up the chimney. The TARM 303 improves upon traditional designs with its firetube heat exchanger, which draws maximum heat from these hot gases.

The TARM 303's large ash door provides easy access to the shaker grate (standard equipment) and ash pit below. The shaker grate is simple and extremely effective — a heavy, cast-iron plate that can be rotated easily from the ash door opening. This grate grinds ash and clinkers into the ash pit below and is impossible to jam.

The firetubes in the TARM 303 are not only efficient heat exchangers but also easy to clean so that they remain efficient. These tubes can be cleaned in a matter of minutes using the 3" round wire brush provided.

All welds on the TARM 303 boiler body are accessible from either the outside or the firebox. The boiler base is removable for access to the interior of the firebox. In the unlikely event that a leak develops late in the life of your boiler, it can be repaired easily by any competent welder.

For heating your tap water, the TARM 303 is available with a tankless coil made of large-diameter copper tubing. This coil provides more output than conventional tankless coils and is also less prone to fouling from mineral deposits. This coil is easily accessible under the top jacket panel. This tankless coil is finned copper tubing for maximum hot tap water production.



TARM 202 and TARM 303 boilers are available built in accordance with the requirements of the ASME Boiler and Pressure Vessel Code.

both systems have these important features . . .

construction

The TARM 202 and TARM 303 boilers are constructed of heavy, boiler plate steel. The doors and the grates are constructed of high-quality cast iron.

The loading door is located at the top of the firebox so that the firebox may be filled completely for long burn times. The lower door provides access to the area directly above the grates and to the ash pit below so that the grates can be cleaned and ash removed with a minimum of effort.

The boiler jacket is heavily insulated and finished in the distinctive HS TARM orange-red baked enamel, a finish often imitated but never duplicated by any other manufacturer of heating equipment. The rounded edges, accurate fit, and smooth, glossy enamel surfaces more resemble the appearance of a quality automobile than the average heating system.

combustion

The TARM 202 and TARM 303 boilers operate as updraft burners. Primary combustion air enters the area below the grates through the air flap in the lower door. The air flap is controlled by an automatic draft regulator, which meters air and accurately maintains boiler water temperature according to heating demand. Since the draft regulator requires no electric power, the

TARM 202 and TARM 303 will continue to control the fire during power failures.

Because all coal fires produce large quantities of burnable gases, it is very important that these gases be burned completely rather than wasted up the chimney. The secondary air inlet in the loading door preheats, then directs air over the coal bed, thus ensuring good secondary burning of these gases.

controls accessories and packing

All TARM 202 boilers are shipped assembled with jacket, grates and doors installed. The boiler is protected by a heavy plastic wrap and a wooden crate. A special poker for clearing ash from the standard grates comes with each boiler. Cast-iron shaker grates are available as an option.

All TARM 303 boiler bodies are shipped strapped to a pallet. A lifting ring is provided on the top of the boiler. The jacket and doors are each boxed separately. When ordered with the TARM 303 boiler, the optional tankless coil comes installed. The coil may be ordered separately and installed easily at a later date.

A separate box containing the following is supplied with all TARM 202 and TARM 303 boilers:

- ASME Boiler Pressure Relief Valve
- Boiler High Limit (Overheat) Control
- SAMSON Automatic Draft Regulator

TARM 202 and TARM 303 boilers are supplied with all necessary cleaning tools at no extra cost.

We recommend that all TARM 202 and TARM 303 boilers be installed with an HS Auto-Mix 4-way mixing valve. The Auto-Mix will help prevent overheating, give greater fuel economy, and increase boiler life. Please consult your dealer for more information.

five-year warranty

All HS TARM boilers carry a limited warranty, a copy of which is provided with the boiler and is available from your dealer.

All coal fires produce large quantities of carbon monoxide, a poisonous gas that is both colorless and odorless. For your safety, please read and understand the entire operating manual before burning coal in your HS TARM boiler.

specifications

		202	303			202	303
Gross Output – Coal	Btu/hr	80,000	120,000	Tapping Numbers			
Max. Hot Water Output	GPM	na	2.4	1 Return	in.	1	1¼
Weight (inc. jacket)	lbs.	450	645	2 Supply	in.	1	1¼
Water Volume	gal.	24	21	4 Tridicator	in.	½	½
Pressure Test	psi.	60	60	10 Boiler Drain			
Pressure Test-Hot				Tapping	in.	½	1¼
Water Coil	psi.	na	250	14 Hot Domestic			
Dimensions				water	in.	na	¾
Width	in.	18	23	15 Cold Domestic			
Depth	in.	19¾	23	water	in.	na	¾
Height (top of				16 Extra Tapping	in.	na	1
jacket)	in.	37	51	18 Extra Tapping	in.	na	1¼
Height (center of				20 Draft			
flue)	in.	na	47	Regulator	in.	¾	¾
Height (top of flue)	in.	39½	na	27 Vent Tapping	in.	na	¾
Firebox Width	in.	12½	17½	Flue Pipe Diameter	in.	6	6
Firebox Depth	in.	14	17½	Minimum Chimney			
Coal Capacity	lbs.	80	135	Draft	in/wg	.05	.05
Loading Door Opening	in.	7½x10	7½x10	Minimum Flue Size	in.	8x8	8x8
Ash Door Opening	in.	10x12	10x12	Minimum Chimney			
				Height	ft.	20	20

TARM 202

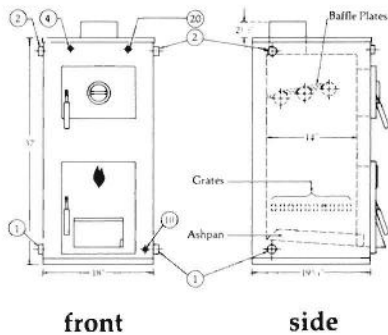

TARM 303

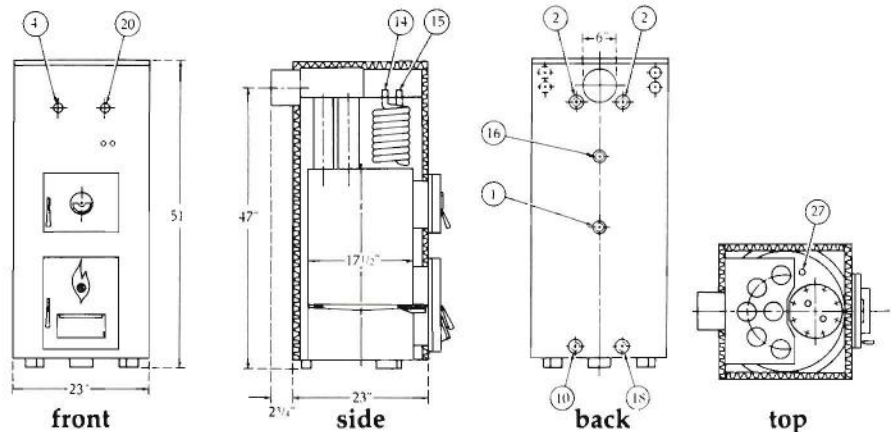

RT. 116, CONWAY, MA 01341