

INDEX

1	DESCRIPTION OF THE APPLIANCE	
1.1	INTRUCTION	16
1.2	SUPPLY	
1.3	DIMENSIONS	
1.4	TECHNICAL FEATURES	
1.5	HEAD LOSSES	
2	INSTALLATION	
2.1	BOILER ROOM	17
2.2	CONNECTION TO THE FLUE	
2.3	CONNECTION OF THE PLANT	
2.4	BRAZIER GRID ASSEMBLY (optional)	
2.5	ASSEMBLY OF THE ACCESSORIES	18
2.6	CASING ASSEMBLY	
2.7	DRAUGHT REGULATOR	
2.8	HYDRAULIC CONNECTION DIAGRAMS	19
3	USE AND MAINTENANCE	
3.1	PRELIMINARY IGNITION CHECKS	20
3.2	CLEANING	
3.3	MAINTENANCE	

1 DESCRIPTION OF THE APPLIANCE

- IT
- PT
- GB**
- SL
- DK
- RO
- RUS
- FR
- BE
- ES
- DE
- HU

1.1 INTRODUCTION

The cast iron "SOLIDA" boilers are a valid solution for the present energetic problems, since they can run with solid fuels: wood and carbon.

"SOLIDA" boilers conform to Directive PED 97/23/CEE.

1.3 DIMENSIONS

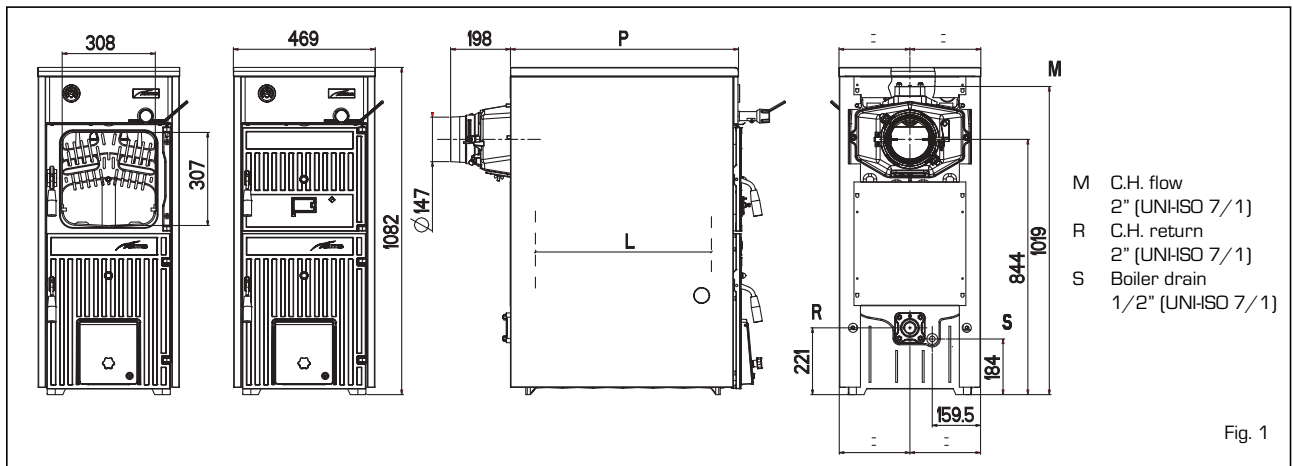

Fig. 1

1.4 TECHNICAL FEATURES

		SOLIDA 3	SOLIDA 4	SOLIDA 5	SOLIDA 6	SOLIDA 7	SOLIDA 8
Carbon heat rate*	kW (kcal/h)	16,3 (14.000)	20,9 (18.000)	25,6 (22.000)	30,2 (26.000)	34,9 (30.000)	39,5 (34.000)
Performance class		1	2	2	2	2	2
Duration of a coal load	h	≥ 4	≥ 4	≥ 4	≥ 4	≥ 4	≥ 4
Duration of a wood load	h	≥ 2	≥ 2	≥ 2	≥ 2	≥ 2	≥ 2
Load volume	dm ³	17,0	25,5	34,0	42,5	51,0	59,5
Minimum chimney depression	mbar	0,08	0,10	0,12	0,13	0,15	0,18
Dimensions							
P (depth)	mm	355	455	555	655	755	855
L (combustion chamber depth)	mm	190	290	390	490	590	690
Number of elements		3	4	5	6	7	8
Max. operating temperature	°C	95	95	95	95	95	95
Min. temperature of water returned to the plant	°C	50	50	50	50	50	50
Max working pressure	bar	4	4	4	4	4	4
Test pressure	bar	6	6	6	6	6	6
Boiler capacity	l	23	27	31	35	39	43
Weight	kg	175	210	245	280	315	350

* The heat rate will be reduced with about 10% for the operation with hard wood (birch - oak - olive).

1.5 HEAD LOSSES

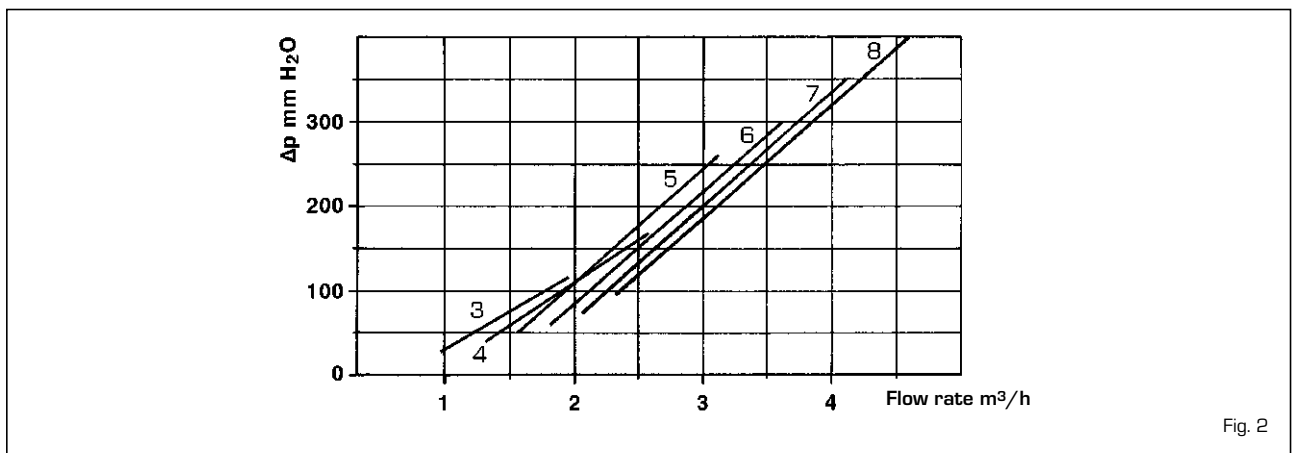

Fig. 2

2 INSTALLATION

2.1 BOILER ROOM

Check that the room has the requirements and features in accordance to the rules in force. Furthermore, the room should be aired, in order to have a regular combustion. Therefore it is necessary to practice some openings in the walls of the room, which correspond to the following requirements:

- They should have a free section of at least 6 cm² for each 1,163 kW (1000 kcal/h). The minimum opening section shouldn't be smaller than 100 cm². The section can also be calculated, using the following ratio:

$$S = \frac{Q}{100}$$

where "S" is expressed in cm².
"Q" is expressed in kcal/h

- The opening should be situated on the lower part of an outer wall, preferably on the opposite of the one for the combustion gas discharge.

2.2 CONNECTION TO THE FLUE

A flue should correspond to the following requirements:

- It should be of waterproof material and resistant to temperature of smokes and related condensations.
- It should be of a sufficient mechanical resistance and a weak thermal conductivity.
- It should be perfectly hermetic in order to avoid cooling of the flue.
- It should have the most possible vertical process and the terminal part should have a static aspirator, which assures an efficient and constant discharge of the combustion product.
- In order to avoid the wind creating a very high pressure around the chimneytop, so that it prevails on the ascensional force of the combustion gas, it is necessary that the discharge orifice hangs over at least 0,4 meters of whatever structure adjacent the chimney itself (including the roof ridge) of at least 8 meters.
- The flue shouldn't have a diameter inferior to the boiler connection; for flues with square or rectangular sections, the internal section should be higher than 10% compared to the boiler connection one.
- The net section of the flue can be obtained from the following ratio:

$$S = K \frac{P}{\sqrt{H}}$$

S section resulting in cm²

K reduction coefficient:

- 0,045 for wood
- 0,030 for carbon

P boiler capacity in kcal/h

H height of the chimney in meters measured from the flame axis at the

exhaust of the chimney in the atmosphere. For the dimensioning of the flue you should consider the effective height of the chimney in meters, measured from the flame axis at the top, diminished with:

- 0,50 m for each direction changing of the connection tube between boiler and flue;
- 1,00 m for each horizontal development meter of the connection itself.

2.3 CONNECTION OF THE PLANT

The connections should be easily disconnected by means of pipelines with revolving joints. It is always advisable to assemble suitable interception shutters on the piping of the heating installation.

CAUTION: It is obligatory to assemble safety valves on the system.

2.3.1 Plant filling

Before starting with the connection of the boiler it is advisable to let the water circulate in the piping, in order to eliminate possible foreign bodies, which could compromise the correct operation of the appliance.

The filling should be carried out slowly in order to make the air bubbles go out through the proper outlets, placed on the heating installation.

The cold loading pressure of the plant and the pre-blowing pressure of the expansion tank, should correspond or however shouldn't be inferior to the height of the static column of the plant in case of closed circuit heating installations (for example, for a

static column of 5 meters, the pre-loading pressure of the tank and the loading pressure of the plant should correspond at least to a minimum value of 0,5 bar).

2.3.2 Features of the feed water

THE TREATMENT OF THE WATER USED FOR THE HEATING INSTALLATION IS ABSOLUTELY NECESSARY IN THE FOLLOWING CASES:

- Very vast plants (with high water contents).
- Frequent replenishment water inlets in the plant.
- If the partial or total emptying of the plant should be necessary.

2.4 BRAZIER GRID ASSEMBLY (optional)

In order to carry out the assembly proceed in the following way (fig. 3):

- Punch the card of the outer part, between the front head and the intermediate element, using a bit of 10 ø as indicated in the detail (B).
- Place the back grid (12) in the combustion chamber.
- Place the front grid (10) and block it to the hub (9) with the screws (8) and the nuts (7); block the front grid from the right side of the boiler body with the screws (5).
- Hook the tie rod (6) to the seats extracted from the front and rear grid.
- Place the intermediate grids (11).
- Introduce the ring (4) and the lever (3) on the hub (9), fixing then everything with the washer (2) and the screw (1).

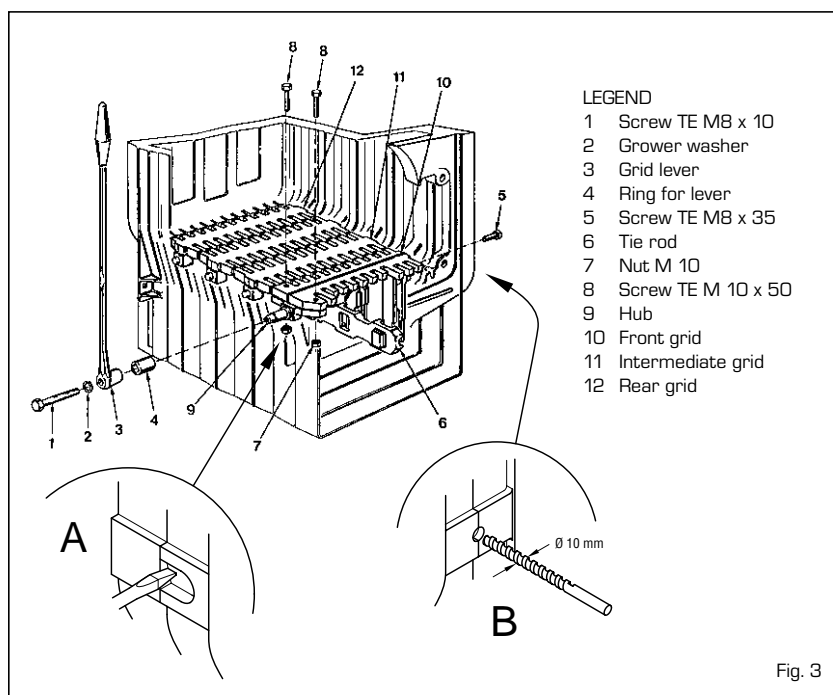

Fig. 3

IT

PT

GB

SL

DK

RO

RUS

FR

BE

ES

DE

HU

IT

PT

GB

SL

DK

RO

RUS

FR

BE

ES

DE

HU

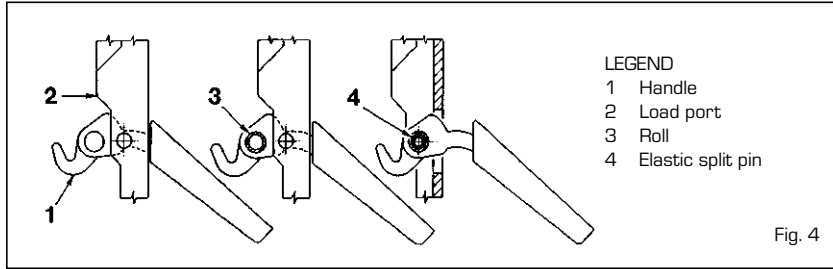

Fig. 4

2.5 ASSEMBLY OF THE ACCESSORIES

The closing handles for the ports and the screw with the adjustment knob for the blast gate damper are supplied separately, since they could be damaged during the transport.

Both the handles and the screws with knob are packed in a nylon bag, introduced inside the ash collection basin.

For the assembly of the handles proceed as following (fig. 4):

- Take a handle [1], insert it in the opening of the load port [2] and introduce the roll [3] in the opening of the handle; block the handle introducing the elastic split pin [4].
- Carry out the same operation for the handle of the ash box port.

To assemble the screw with the knob, proceed as follows (fig. 5):

- Remove the screw M8 x 60, which fixes the air blast damper to the ash box port and screw the screw with the bakelite knob [1] on, which is supplied in the packaging.
- Place the blind nut with cap [2] at the end of screw M 10.
- Fix lever M6 to the air blast damper [3] placing it in a horizontal direction on the right. The lever has an opening at its end, where the chainlet of the thermostatic regulator will be connected.

2.6 CASING ASSEMBLY

Two superior tie rods are screwed on three nuts at the front side of the boiler: the second and the third nut serve to place correctly the lateral sides of the casing.

Two nuts one to fix the clamp holders for the lateral sides are screwed on the inferior tie rods, both from the front side and from the rear side of the boiler. The assembly of the casing components has to be carried out in the following way (fig. 6):

- Unscrew with some rotations the second or third nut of each tie rod.
- Hook the left side [1] on the lower tie rod and superior of the boiler and adjust the position of the nut and locknut of the upper tie rod.
- Fix the lateral side in blocking the locknut.
- In order to assembly the right side [2] proceed in the same way.
- Hook the front upper board [3] introducing the two splines in the opening, obtai-

ned on each side.

- Carry out the same operation to fix the back lower board [4].

- The protection deflector [5] is fixed to the control board [6] with three self-threading screws.

Fix the board by means of the pressure stakes.

Then unwind the capillary of the thermometer and introduce it in the left sheath of the posterior head, introducing the contact spring.

The right sheath can be needed for the check thermometer.

- Fix the cover [7] at the lateral sides of the boiler.

NOTE: Keep the "Test certification" together with the boiler documents in the combustion chamber.

2.7 DRAUGHT REGULATOR

The boilers "SOLIDA" can assemble indifferently 2 types of thermostatic regulators.

NOTA:

In order to fix the lever with the chainlet in the regulator holder it is necessary to remove the deflector in aluminum, which is assembled on the control board, by unscrewing the three screws that fix it. (fig. 6)

Replace the protection deflector after the

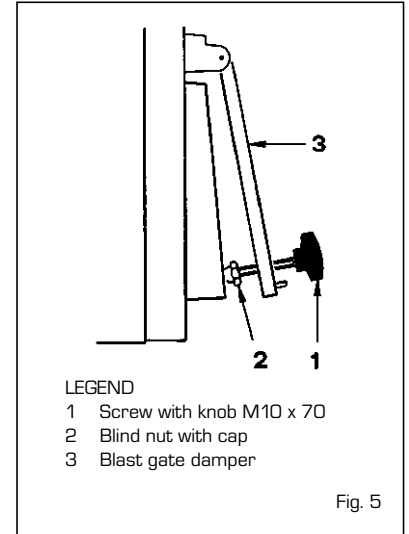

Fig. 5

assembling and related adjustment.

2.7.1 "THERMOMAT RT-C" Regulator

The "Thermomat" regulator is equipped with a thermosetting resin knob of an adjustment field from 30 to 100 °C (fig. 7).

Screw the regulator on the 3/4" opening of the anterior head and orientate the red index on the upper part.

The lever with the chainlet should be introduced in the regulator holder after having assembled the instrument holder board and after having removed the plastic lock.

If the joint is taken out, which fixes the lever with the chainlet, take care in assembling it again in the same position.

After having placed the knob at 60°C, block the lever with the chainlet in a slightly inclined position downwards, so that the chainlet will be in axis with the air gate damper.

For the adjustment of the "Thermomat", which essentially consists in the determina-

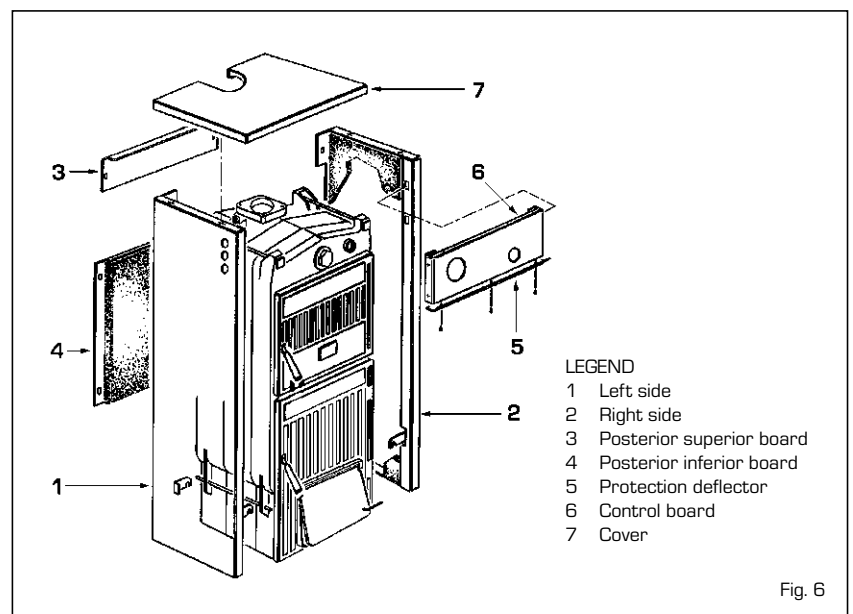

Fig. 6

tion of the chainlet length, proceed in the following way:

- Place the knob at 60°C.
- Switch on the boiler with opened air gate damper.
- When the water temperature of 60° C is reached in the boiler; fix the chainlet in such a way on the lever of the air gate damper; in order to obtain an opening of about 1 mm.
- Now the regulator is calibrated and it is possible to choose the desired operating temperature by rotating the knob.

2.7.2 "REGULUS RT2" Regulator

The adjustment field is included between 30 and 90°C (fig. 8).

Follow the same instructions of the "Thermomat" regulator for the assembly and the activation.

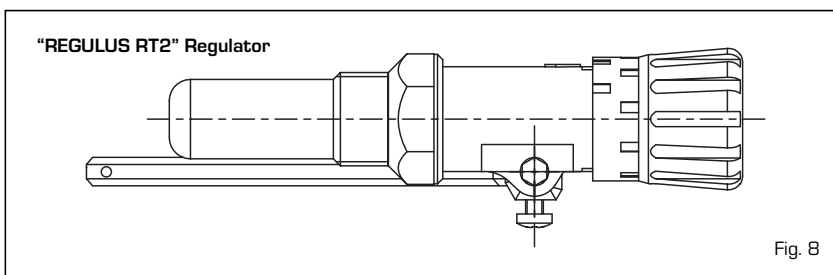
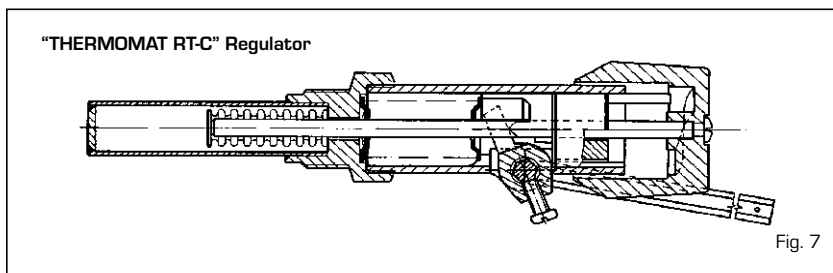

2.8 HYDRAULIC CONNECTION DIAGRAM

2.8.1 Open expansion tank system

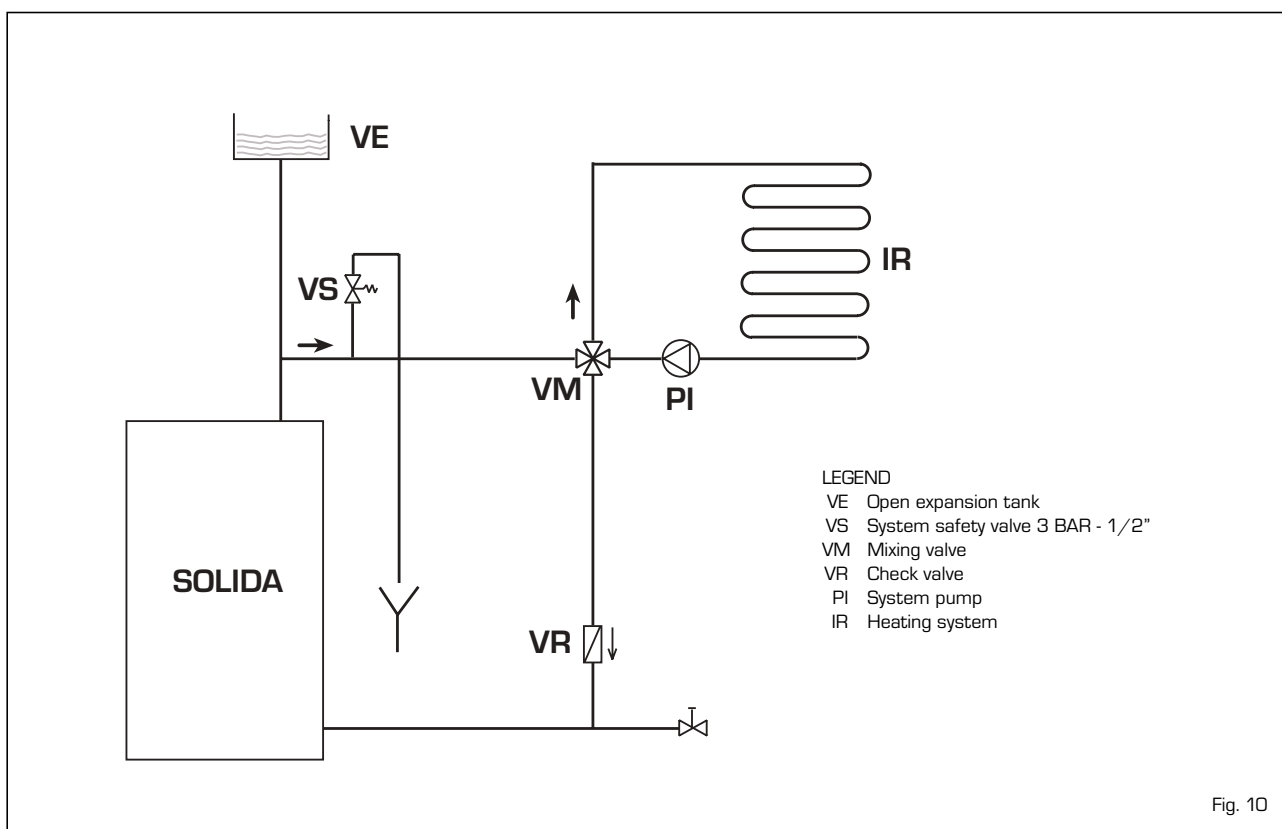

IT

PT

GB

SL

DK

RO

RUS

FR

BE

ES

DE

HU

2.8.2 Closed expansion tank system with heat exchanger and optional thermostat valve

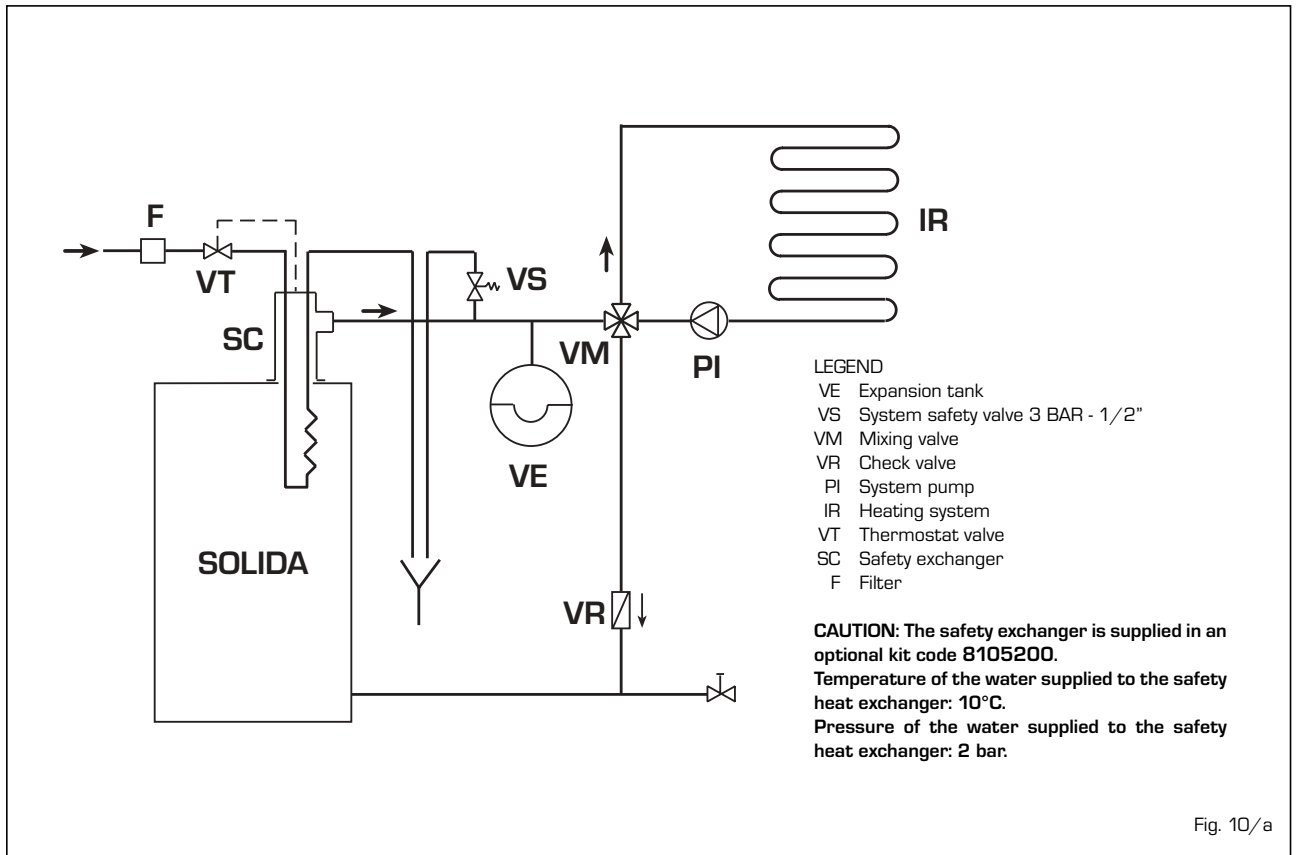

Fig. 10/a

3 USE AND MAINTENANCE

3.1 PRELIMINARY IGNITION CHECKS

Before the use of the boiler, it is necessary to follow the following instructions:

- The installation where the boiler is connected to, should be preferably with an open expansion tank (fig. 10).
- The tube, which connects the boiler to the expansion tank, should have an adequate diameter according to the norms in force.
- The heating pump should always be running during the operation of the boiler.
- A possible ambient thermostat should never interrupt the pump operation.
- If the installation is equipped with a 3 or 4 ways mixing valve, it should always be placed in the opening position toward the installation.
- Be assure that the draught regulator works regularly and that there aren't impediments, which block the automatic operation of the air gate damper.

3.2 CLEANING

The cleaning should be carried out with a

certain frequency providing besides the cleaning of the smoke passages, also the cleaning of the ash box, removing the ashes, which are contained in the collection basin. Use a proper pull-through for the cleaning of the smoke passages (fig. 11).

3.3 MAINTENANCE

Do not perform any maintenance work, dismantling or removal of parts without properly emptying the boiler first. The boiler must not be emptied when the water is hot.

CAUTION:

The safety valve on the system must be inspected by technically qualified personnel every five years.

If the system is completely emptied and remains unused for some time, the safety valve must be inspected before it is used again.

If the safety valve should malfunction and cannot be re-calibrated, replace it with a new 1/2" valve calibrated to 3 BAR and conforming with Directive PED 97/23/CEE.

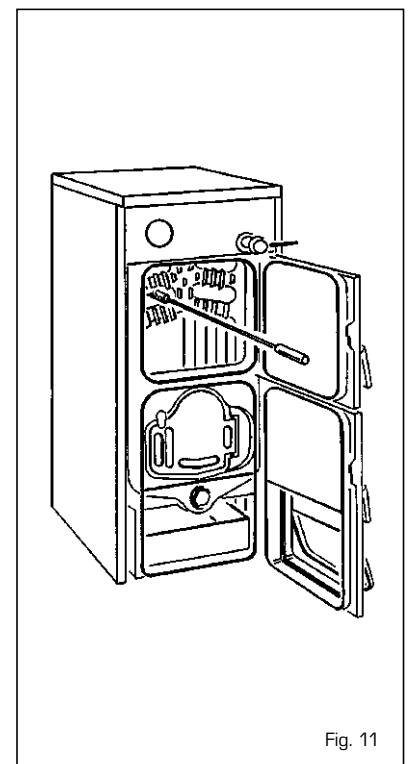

Fig. 11